

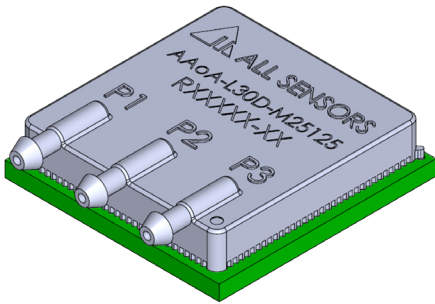

## AAoA Triple Pressure Sensor Series

### High-Precision Airflow and Barometric Sensing for Accurate Angle of Attack Measurement



#### Table of Contents

Features & Applications.....	2
Standard Pressure Ranges .....	2
Pressure Sensor Maximum Ratings.....	2
Environmental Specifications .....	2
Electrical Block Diagram.....	3
Internal Pressure Connections .....	3
Performance Characteristics.....	4
I2C / SPI Electrical Parameters.....	5
Pressure Output Transfer Function Example .....	5
Temperature Output Transfer Function .....	5
Extended Compensation Instructions.....	6
Additional Application Information .....	6
Package Drawing.....	7
How to Order .....	8
Pad Layout .....	8
Product Identification .....	8

**Amphenol All Sensors AAoA Series** is purpose-built to meet the demanding requirements of Angle of Attack (AoA) applications across a broad range of platforms, including military and civil aviation, guided and air-to-air missiles, commercial and defense UAVs, and emerging Urban Air Mobility (UAM) and swarming drone systems.

These compact sensors integrate high-accuracy differential and absolute pressure sensing with temperature measurement, enhanced by advanced temperature compensation and linearity correction. The result is precise, stable performance in mission-critical environments where reliability is essential.

Optimized for seamless integration into AoA systems, the AAoA Series features a compact, leadless, PCB-mountable design compatible with automated SMT assembly. Digital output options include both I<sup>2</sup>C and SPI interfaces, while the low-profile side-port configuration requires only three connections—minimizing space, weight, and system complexity.

**Contact us to learn how the AAoA Series can enhance your next Angle of Attack design.**



## Features

- Internal pressure manifolding to eliminate external pressure tubing connection between sensors
- Simultaneous Precision Measurement of two differential pressure and one absolute pressure sensor as well as temperature
- Wide Operating Temperature Range for Harsh Environments
- 24-bit High Resolution
- I<sup>2</sup>C or SPI Output Interfaces for all 3 sensors
- Compact and Lightweight Design
- Leadless Surface Mount Design compatible with SMT Automated Assembly
- Fully Customizable for OEM applications

## Applications

- Military / Defense Aviation
- Civil Aviation
- Guided Missiles
- Air-to-air missiles
- Commercial, Defense, & Industrial Drones
- Swarming Drones
- Urban Air Mobility (UAM) systems

### Standard Pressure Ranges

Device	Differential Operating Range <sup>A</sup>	Absolute Operating Range <sup>A</sup>	Proof Pressure		Burst Pressure	
			inH2O	kPa	inH2O	kPa
AAoA-L05D-M25125	± 5 inH2O	250 mbarA - 1250 mbarA	270	67	415	103
AAoA-L10D-M25125	± 10 inH2O	250 mbarA - 1250 mbarA	300	75	415	103
AAoA-L30D-M25125	± 30 inH2O	250 mbarA - 1250 mbarA	350	87	415	103
AAoA-L60D-M25125	± 60 inH2O	250 mbarA - 1250 mbarA	350	87	415	103
AAoA-L100D-M25125	± 100 inH2O	250 mbarA - 1250 mbarA	350	87	415	103

Note A: Consult Factory for Additional Pressure Ranges

Pressure Sensor Maximum Ratings		Environmental Specifications	
<b>Supply Voltage (Vs)</b>	5.5 Vdc	<b>Temperature Ranges</b>	
<b>Common Mode Pressure</b>	50 psig	Compensated:	-40°C to 85°C
<b>SMT Device Temperature</b>	245°C	Operating	-40°C to 85 °C
		Storage	-40°C to 125 °C
		<b>Humidity Limits (non condensing)</b>	0 to 95% RH

## Electrical Block Diagram

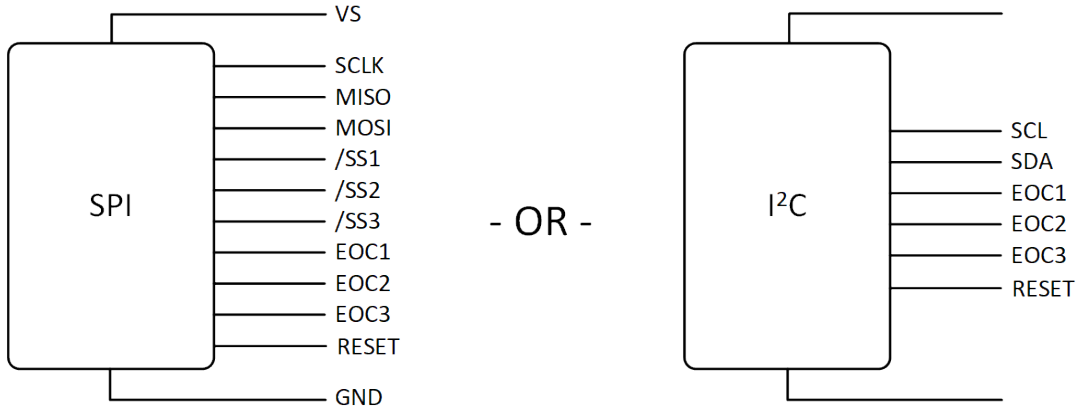

## Internal Pressure Connections

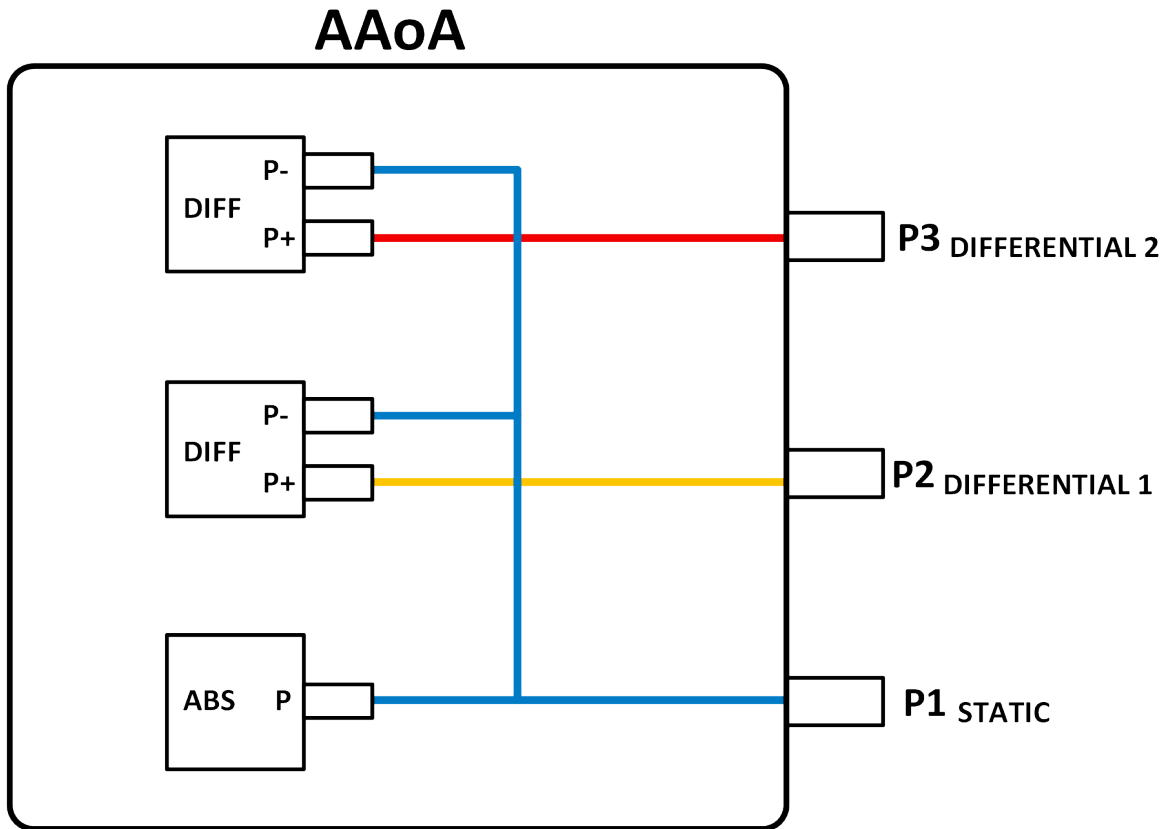

## Performance Characteristics for AAOA Series High Accuracy Pressure Sensors

All Parameters are measured at 3.3V  $\pm$ 10% excitation and 25°C unless otherwise specified (Note 9). Differential Pressure measurements are with positive pressure applied to Ports P2 and P3. Absolute Pressure measurements refer to Port P1.

Parameter	Symbol	Min	Typ	Max	Units	Notes
<b>Output Span</b>						
Differential Channel	Span <sub>dig</sub>	-	$\pm 0.4 * 2^{24}$	-	Dec Count	1
Absolute Channel	Span <sub>dig</sub>	-	$0.8 * 2^{24}$	-	Dec Count	1
<b>Offset Output @ Zero Diff./ Abs. Pressure</b>						
Differential Channel	OS <sub>dig</sub>	-	$0.5 * 2^{24}$	-	Dec Count	-
Absolute Channel	OS <sub>dig</sub>	-	$0.1 * 2^{24}$	-	Dec Count	-
<b>Error Summary</b>						
L05D - Differential Channel						
Total Error Band [ 85C to -20C ]	TEB <sub>p</sub>	-	-	$\pm 0.25$	%FSS	2, 6
Total Error Band [ -20C to -40C ]	TEB <sub>p</sub>	-	-	$\pm 0.45$	%FSS	2, 6
Accuracy	Acc <sub>p</sub>	-	-	$\pm 0.10$	%FSS	3, 6
L10D - Differential Channel						
Total Error Band [ 85C to -20C ]	TEB <sub>p</sub>	-	-	$\pm 0.20$	%FSS	2, 6
Total Error Band [ -20C to -40C ]	TEB <sub>p</sub>	-	-	$\pm 0.40$	%FSS	2, 6
Accuracy	Acc <sub>p</sub>	-	-	$\pm 0.10$	%FSS	3, 6
L30D / L60D / L100D - Differential Channel						
Total Error Band [ 85C to -20C ]	TEB <sub>p</sub>	-	-	$\pm 0.15$	%FSS	2, 6
Total Error Band [ -20C to -40C ]	TEB <sub>p</sub>	-	-	$\pm 0.35$	%FSS	2, 6
Accuracy	Acc <sub>p</sub>	-	-	$\pm 0.10$	%FSS	3, 6
Absolute Channel - All variants						
Total Error Band [ 85C to -20C ]	TEB <sub>p</sub>	-	-	$\pm 0.25$	%FSS	2, 6
Total Error Band [ -20C to -40C ]	TEB <sub>p</sub>	-	-	$\pm 0.45$	%FSS	2, 6
Accuracy	Acc <sub>p</sub>	-	-	$\pm 0.10$	%FSS	3, 6
<b>Offset Position Sensitivity (<math>\pm 1g</math>)</b>						
	Sen <sub>pos</sub>	-	$\pm 0.10$	-	%FSS	-
<b>Offset Long Term Drift (one year)</b>						
	LTOS	-	$\pm 0.25$	-	%FSS	-
<b>Pressure Digital Resolution - No Missing Codes</b>						
	Res <sub>Pa<sub>dc</sub></sub>	17.2	-	-	bit	-
<b>Temperature Output</b>						
Resolution (internal)	Res <sub>Tadc</sub>	-	13	-	bit	-
Overall Accuracy	Acc <sub>T</sub>	-	-	$\pm 2$	°C	-

### Electrical Specification:

<b>Supply Voltage</b>	V <sub>S</sub>	2.7	3.3	3.6	V <sub>dc</sub>	9
<b>Supply Current Requirement</b>						5, 7, 8
During Active State	ICC <sub>Active</sub>	-	9.0	10.5	mA	-
During Idle State	ICC <sub>Idle</sub>	-	4.5	18.0	μA	-
<b>Power On Delay</b>	t <sub>pwron</sub>	-	-	2.5	ms	5
<b>Memory Read Access Time</b>	t <sub>rd</sub>	-	100	2000	μs	4
<b>Data Update Time</b>	t <sub>du</sub>		(see table below)			5, 7

Channel	Measurement Command										Units
	Single		Average2		Average4		Average8		Average16		
	Typ	Max	Typ	Max	Typ	Max	Typ	Max	Typ	Max	
Differential	2.0	2.2	3.8	4.2	7.4	8.2	14.6	16.2	29.0	32.1	ms

### Specification Notes

- NOTE 1: THE SPAN IS THE ALGEBRAIC DIFFERENCE BETWEEN FULL SCALE DECIMAL COUNTS AND THE OFFSET DECIMAL COUNTS. THE FULL SCALE PRESSURE IS THE MAXIMUM POSITIVE CALIBRATED PRESSURE.
- NOTE 2: TOTAL ERROR BAND (TEB) IS THE COMBINATION OF ERRORS INCLUDING OFFSET, SPAN, LINEARITY, PRESSURE HYSTERESIS, TEMPERATURE EFFECT ON OFFSET, AND TEMPERATURE EFFECT ON SPAN.
- NOTE 3: ACCURACY INCLUDES PRESSURE HYSTERESIS, REPEATABILITY AND BEST-FIT STRAIGHT LINE LINEARITY, EVALUATED AT 25C.
- NOTE 4: DELAY BETWEEN END OF MEMORY READ REQUEST COMMUNICATION AND START OF MEMORY DATA READ COMMUNICATION.
- NOTE 5: PARAMETER IS CHARACTERIZED AND NOT 100% TESTED.
- NOTE 6: EVALUATED FOLLOWING CORRECTIONS DESCRIBED IN EXTENDED COMPENSATION SECTION.
- NOTE 7: DATA UPDATE TIME IS EXCLUSIVE OF COMMUNICATIONS, FROM COMMAND RECEIVED TO END OF BUSY STATUS. THIS CAN BE OBSERVED AS EOC PIN LOW- STATE DURATION ON ABSOLUTE CHANNEL, OR AS DELAY TO EOC PULSE ON DIFFERENTIAL CHANNEL.
- NOTE 8: AVERAGE CURRENT CAN BE ESTIMATED AS :  $ICC_{idle} + (t_{DU} / \text{READING INTERVAL}) * ICC_{Active}$ . REFER TO FIGURE 2 FOR ACTIVE AND IDLE CONDITIONS OF THE SENSOR.
- NOTE 9: THE SENSOR IS CALIBRATED WITH A 3.3V SUPPLY HOWEVER, AN INTERNAL REGULATOR ALLOWS A SUPPLY VOLTAGE OF 2.7V TO 5.5V TO BE USED WITHOUT AFFECTING THE OVERALL SPECIFICATIONS. THIS ALLOWS DIRECT OPERATION FROM A BATTERY SUPPLY.

## I2C / SPI Electrical Parameters

Parameter	Symbol	Min	Typ	Max	Units	Notes
Input High Level	-	70	-	100	% of VS	5
Input Low Level	-	0	-	30	% of VS	5
Output Low Level (at 3mA sink)	-	-	-	10	% of VS	5
I2C Pull-Up Resistor	-	1000	-	-	Ω	5
I2C Load Capacitance on SDA, @ 400 kHz	C <sub>SDA</sub>	-	-	200	pF	5
I2C Input Capacitance (each pin)	C <sub>I2C_IN</sub>	-	-	10	pF	5
<b>I2C Address:</b>						
Absolute Channel P1	Iadr <sub>Abs</sub>	-	37	-	dec	-
Differential Channel P2	Iadr <sub>Dif1</sub>	-	38	-	dec	-
Differential Channel P3	Iadr <sub>Dif2</sub>	-	39	-	dec	-

## Pressure Output Transfer Function - Example

$$\text{Differential Pressure} = 1.25 \times \left( \frac{P_{dig} - 2^{23}}{2^{24}} \right) \times \text{Cal Range}$$

Where:

$P_{dig}$  is the sensor 24-bit output, following corrections applied by extended compensation  
**CalRange** is 2x the calibrated differential pressure range: eg. for L05D is 10 inH2O

$$\text{Absolute Pressure} = 250 \text{ mbar} + 1.25 \times \left( \frac{P_{dig} - (0.1 \times 2^{24})}{2^{24}} \right) \times 1000 \text{ mbar}$$

Where:

$P_{dig}$  is the sensor 24-bit output, following corrections applied by extended compensation

## Temperature Output Transfer Function

$$\text{Temperature (*C)} = \left( \frac{Tout_{dig} * 200}{2^{24}} \right) - 50$$

Where:

$Tout_{(dig)}$  The sensor 24-bit digital temperature output.

## Extended Compensation Instructions

---

AAoA Series sensors have internal memory locations containing extended compensation coefficients. For optimal accuracy of pressure readings, system designers can use these values to apply an additional 3rd-order error-correction adjustment to data delivered from the sensor, as well as additional temperature compensation.

### Theory of Extended Compensation:

The four linearity coefficients are programmed for each channel of the sensor at the factory as a 3rd order minimization solution to

$$(1) \quad \text{Error} = \text{Pref} - (\text{POut} + f(\text{POut})),$$

where  
Pref is the true pressure applied;  
POut is the sensor output;  
f(POut) is a cubic correction function,  $Ax^3+Bx^2+Cx+D$ .

Then

$$(2) \quad \text{Pcorr} = \text{Pout} + f(\text{Pout}) \text{ as the linearity-corrected pressure value.}$$

For improved accuracy over temperature, residual temperature dependent errors are minimized by the term:

$$(3) \quad \text{TCadj} = (1 - (\text{Es} * 2.5 * |0.5 - \text{Pcorr}|)) * (\text{T} - \text{Tref}) * \text{TC50}$$

where:

$$\text{TC50} = \text{TC50H}/\text{TC50Scale} \text{ for } \text{T} > \text{Tref}$$
$$\text{TC50} = \text{TC50L}/\text{TC50Scale} \text{ for } \text{T} < \text{Tref}$$

and

$$\text{TC50Scale} = 100 * 100 * 167772.$$

This represents the possible range of temperature-dependent error, scaled to temperature counts.

Then

$$(4) \quad \text{Pcomp} = \text{Pcorr} - \text{Tcadj}$$

for the final optimized pressure value. This is used in the Pressure Output Transfer Function on Page 5 to obtain pressure in appropriate units.

## Additional Application Information

---

### Assembly Recommendations:

AAoA devices are non-hermetic and should be handled in accordance with IPC/JEDEC standard J-STD-020 classification MSL-4: SMT assembly or other high-temperature processing must be performed within 72 hours of opening factory-sealed packaging, in an environment of < 30C / 60% RH.

Beyond this interval, a bake process at 125C for 24h is required.

If a PCBA cleaning process is required, parts must not be immersed or subject to compressed air. If necessary, manual cleaning is recommended. No foreign matter of any kind may enter the pressure ports.

If secondary system calibration is to be performed, allow 48 hours for settling after SMT exposure.

Package Drawing [inches]

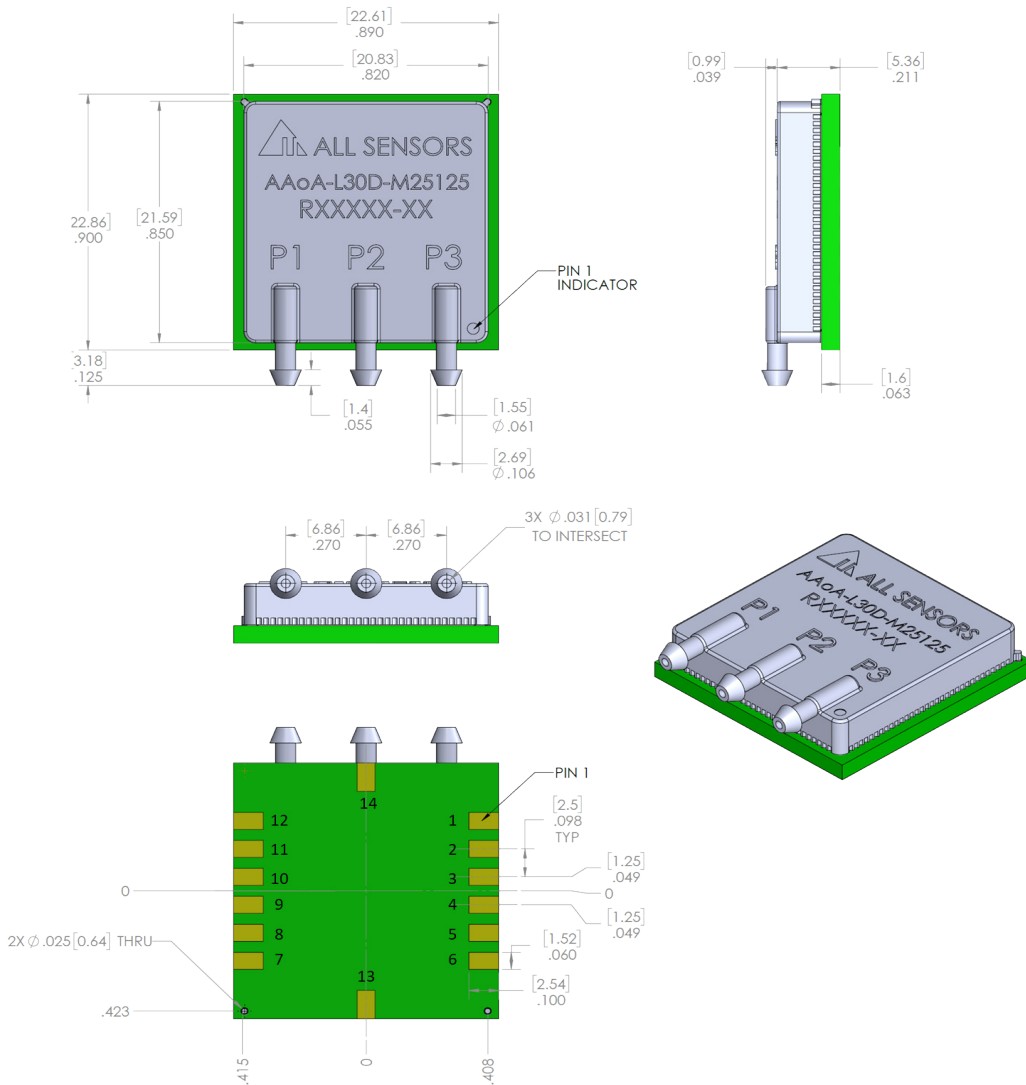

Pin	Symbol	Description
1	VS	Power Supply
2	SCL/SCLK	Clock for I2C or SPI
3	SDA/MOSI	Data I/O for I2C, Data Input for SPI
4	MISO	Data Output for SPI
5	RESET	Digital IC reset (Low active); internal pull-up
6	GND	Power Supply Ground
7	/SS1	For SPI, Slave Select to enable Absolute Channel P1 output
8	EOC1	End of conversion for Absolute P1: 5usec positive pulse when reading complete
9	/SS2	For SPI, Slave Select to enable Differential Channel P2 output
10	EOC2	End of conversion for Differential P2: 5usec positive pulse when reading complete
11	/SS3	For SPI, Slave Select to enable Differential Channel P3 output
12	EOC3	End of conversion for Differential P3: 5usec positive pulse when reading complete
13	GND	Power Supply Ground
14	GND	Power Supply Ground



## How to Order AAoA Series

For example, **AAoA-L30D-M25125-RR-N** defines an All Sensors AAoA Series pressure sensor with 30 inH2O differential pressure and 250 to 1250 mbar absolute pressure range, RR package (SMT with two barbed side ports), and no coating options.

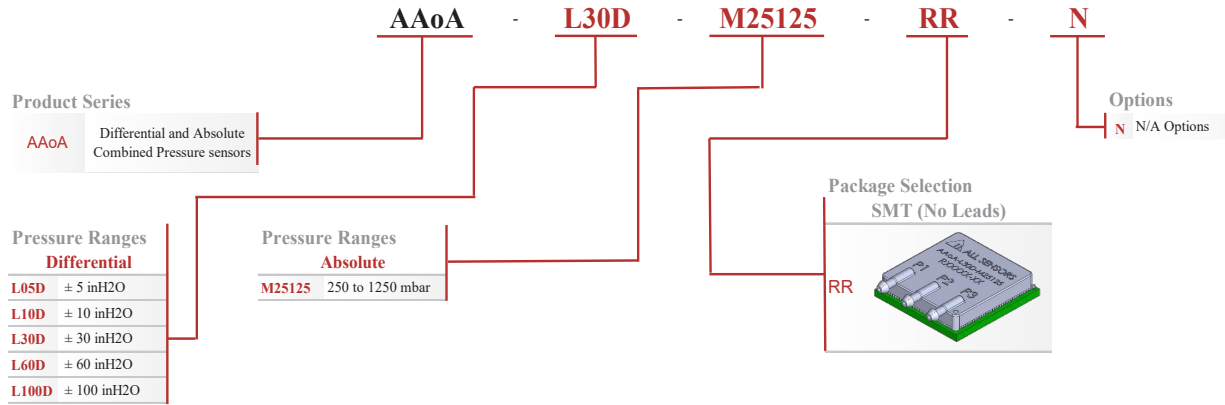

## Pad Layout

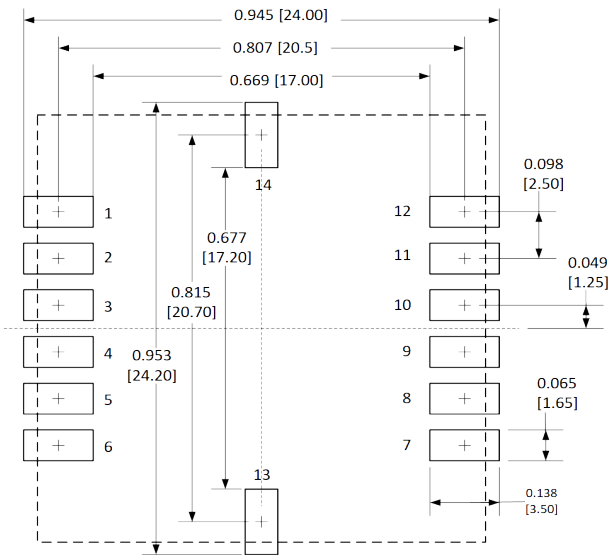

## Product Identification

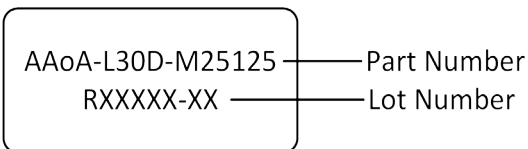

All Sensors reserves the right to make changes to any products herein. All Sensors does not assume any liability arising out of the application or use of any product or circuit described herein, neither does it convey any license under its patent rights nor the rights of others.

